

Part #: ECM7387LS

1973-87 Chevy C10 LS Engine Conversion Brackets

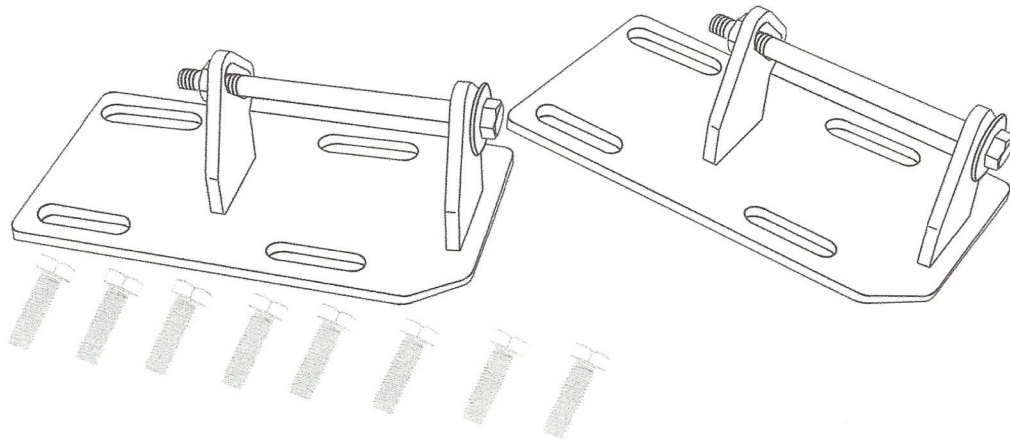

Installation Instructions:

1. Remove the factory motor mount bolts and motor mounts from your LS engine.
2. Install the adapter brackets with the supplied flange head bolts.
3. Re-torque to factory torque specs. 37 ft lbs
4. These mounts are adjustable. Adjust to fit your engine to your needs.
5. Install your engine and attach to the factory clam shell pads with the supplied engine mount bolts.
6. Torque engine mount bolts to factory specs - 59 ft lbs

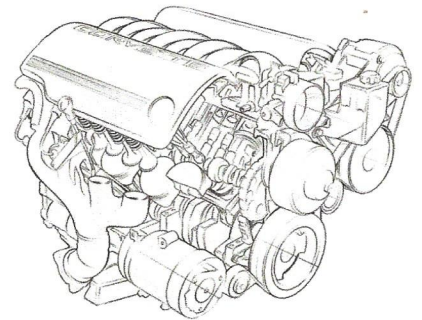

Kit Includes:

- 2 - Engine Mount Brackets
- 2 - 7/16"-14 x 5-1/2" Bolt, GR5
- 2 - 7/16" SAE Flat Washer
- 4 - 7/16-14 Nut, GR5
- 8 - 10mm-1.5 x1-1/8" Flange Head Bolt

TORQUE SPECIFICATIONS

Normal Torque for Tightening
Stud Nuts and Bolts
Stud or Bolt Tightening Torque

DIAMETER	IN. LBS	FT. LBS
1/4	55-85	4.5-7
5/16	110-165	9-14
3/8	190-285	16-24
7/16	295-445	25-37
1/2	450-680	38-57
9/16	640-970	53-81
5/8	880-1300	73-110

Tech Support: tech@performanceonline.com